

---

# Be Serious about Antenna Experimenting

By Anselmo Stiffan IZ3BGJ

---

## INTRODUCTION

The search for the miracle antenna for the HF bands has motivated several antenna enthusiasts to develop and investigate new shapes and new theories. In most cases fabulous performances were claimed; see for instance the many articles and forums boosted by the CFA, EH, DLA and many other small exotic antennas. Several individuals were delighted with the contacts they made with these antennas and announced their good experience to the entire world. The initial welcoming of the radio ham community has often faded because of erratic performances reported or emotional, more than technical, polemics.

In my opinion the individual in seeking a small antenna has, in most cases, not enough space to raise a well-established full size antenna. This simple fact is the main cause of the illusion of great performance when one of these novelties are used; being unable to compare the exotic antenna against a good full size antenna, the radio contacts become the only performance proof. Even with the ability to test a new antenna against a classical half-wave dipole may raise serious doubts because only rarely is a dipole installed in ideal conditions: it may be low above ground, may have unbalanced currents, may be surrounded by interfering objects, etc. Furthermore the understanding of the line radiation, often the only radiating part of the antenna, is shortcoming.

Carrying out serious tests on these antennas has demonstrated that there is no miracle at all; instead, the measured performance values are always relatively poor. So what is wrong? Why do the tests not confirm the field results or feelings? Why can't we individually assess the real performance of an antenna before we enthusiastically announce a break-through?

## HF Antenna Evaluation

Good books like the "The antenna experimenter's guide" of Peter Dodd G3LDO edited by the RSGB of UK or good projects like the CIAO RADIO published in this magazine or articles written by LB Cebik offer really good suggestions on how to test the REAL performances of antennas. These good method have however the drawback of insufficient room to run correctly the tests. All directions apply to actual size antennas that for the HF bands are often too large to fit in the average environment.

Most of us are limited in space and alternate solutions have to be proposed.

Claudio Re has published in this magazine reliable evaluation tests using the "TEST RANGE" method where the antenna under test is compared with an almost perfect reference. The space problem is overcome by scaling the test system to higher frequencies: in his case the operation is in the 6-meter band requiring a proportionally reduced space.

Accepting his suggestions, I chose to build a TEST RANGE operating in the 2-meter band because my available space is about 10 meters. In fact the required space is approximately nine square wavelengths; it is a dramatic space reduction but still unavailable to many experimenters. A further increase of the operation frequency would reduce further the required space, but another factor imposes a limit: the size of the tested antenna. Since the search is aimed toward small antennas with a maximum size of 1/20th of wavelength, we realize that at 145 MHz such a size is 10 cm or 4 inches. It is quite difficult to build a perfectly scaled antenna when it involves coils, capacitors, precise shapes, etc. I believe that 145 MHz is the maximum frequency suited for this test method.

## The 145-MHz Test Range

A test range consists of two identical ground independent reference antennas spaced by at least two wavelengths and a set of measurement instruments. A two-wavelength space around each antenna is required. The antenna to test has to be built for the test range frequency (in this case 145 MHz).

I built two ground plane antennas resonant at the same frequency with a perfect 50-ohm match. The photo below shows these two antennas.



I have sufficient space to install them some 5 meters apart which guarantees a high attenuation of the near field and they can also be suspended more than two meters above the ground whenever the antenna under test is not ground independent, like dipoles, loops etc.

I am lucky to live in a country house with plenty of room and a high roof as the photo above displays. I can hang the small antennas to the roof with a nylon string, making their environment similar to a free space. You may notice however that a 145 MHz test range still requires an amount of space not available to many experimenters, explaining why only a minority can perform a serious test.



The transmitting antenna has to be fed with an amplitude and frequency stable signal while the receiving one is connected to a receiver via a switchable attenuator. The receiver needs to have an S-meter with a good resolution (no need for high precision). In my case I connected a digital multimeter to the analog S-meter internal wiring. **Figure 1** shows the connections of the system.

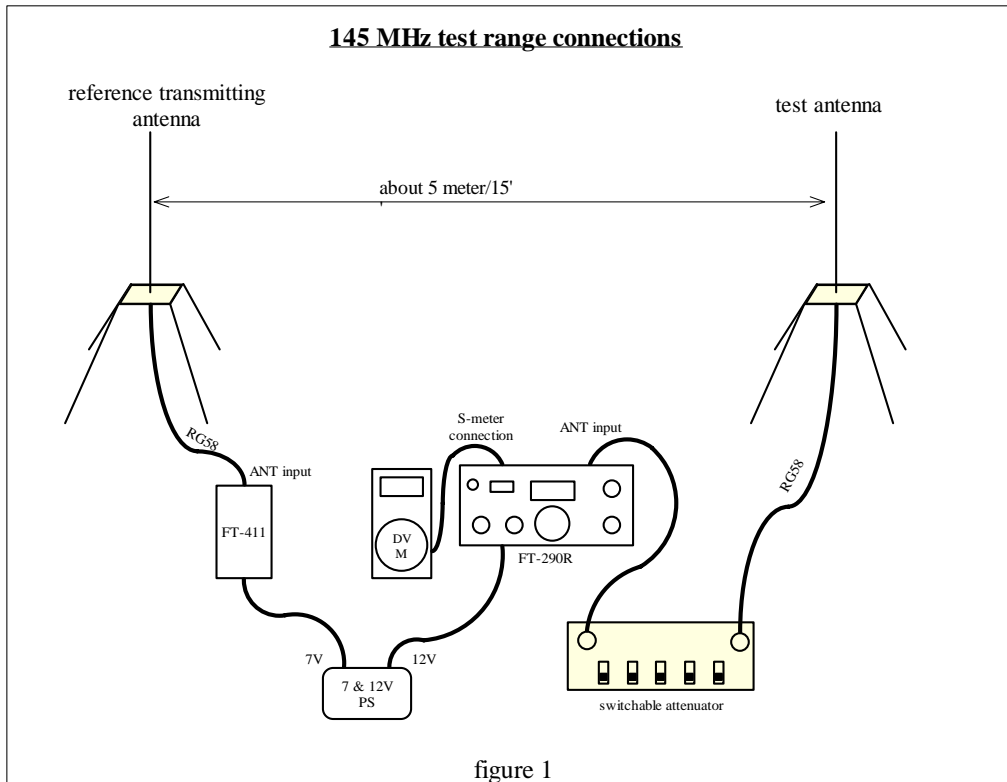

### Test Procedure

The antenna under test is connected to the digital attenuator and positioned at least 4 meters away from the reference transmitting antenna. No obstacle or metal objects are tolerated nearby the antennas. Assuming that the antenna under test has a lower gain than a GP, the test procedure is as follows:

1. Excite the transmitting antenna with a continuous very stable signal.
2. Set the attenuator to 0 dB and tune the receiver on the transmitted signal.
3. If necessary, adjust the transmitted signal with an attenuator to bring the receiver S-meter somewhere within its range.
4. Take note of the S-meter voltage as measured by the digital multimeter.
5. Replace the antenna under test with the reference ground plane.
6. Adjust the digital attenuator until the S-meter reading is the same as at point 4.
7. The attenuator reading is the test antenna gain loss against a GP.

In case the antenna under test has an expected gain higher than a ground plane, then point 2 through point 4 will have to be performed with the test antenna while the points 5 through 7 will be performed with the reference ground plane. The attenuator reading will be the test antenna gain against the GP.

Whenever the test antenna is expected to have directivity in any of its axis, the tests have to be repeated changing the position of the test antenna to assess its gain at the various angles. This set of measurements can be used to draw the radiation pattern.

## The Equipment

**The signal generator:** I use my little FT-411 transceiver set to low power and supplied with a 7V power supply.



The FT-411



The FT-290R with the digital multimeter connected to the S-meter terminals



The switchable attenuator

**The receiver:** I have an old FT-290R where I brought-out the S-meter leads.

**The attenuator:** I built the attenuator using the directions of the *ARRL Antenna Book*, chapter 27, but limited its range to 20dB because I think that any antenna having a loss greater than -20dB is of little interest.

### Recommendations

There are no critical issues to mention or high difficulties in making the set-up. The only problem I had was the construction of the GP

antennas. In fact they were exactly identical but resonate at different frequencies. After deep investigation I found the reason: the male PL connectors were not made by the same manufacturer and were inserting a different capacity at the base of the stylus. Once replaced, everything was in order.

A last word about the impedance adjustments of the antennas: this is achieved by modifying the angle that the radials form with the stylus. The higher the angle, the higher will be the impedance.

### Conclusions

Once again, the difficulties in assessing correctly the performances of HF antennas are, above all, the availability of enough room to accommodate properly the system.

Experimenting with very small antennas like magnetic loops, it would be advisable to set-up a test range at lower frequencies. In fact a magnetic loop for the 145 MHz band will be about 10 cm or four inches in diameter making its adjustments somewhat difficult. At 50 MHz, it will have a more handy size of about 30-40 cm (12-16 inches) diameter. **-30-**

---

### **Brief biography of Anselmo Stiffan, IZ3BGJ, ex HB9ICK:**

I graduated in Electrical Engineering in 1960, and worked for 3 years in the Olivetti research labs for the development of high-speed computer core memories. I spent 6 years at STMicroelectronics and 24 years in Motorola Semiconductors dealing successively with all kind of semiconductors from diodes to microprocessors and custom designs as International Product Marketing Manager.

I received my first radio license in 1962 as I1STA but, due to intense traveling across the world and family duties, was radio inactive for 30 years until I took an early retirement. Getting back to the radio world with the call IZ3BGJ, I have dedicated my investigations to the antenna field, which was previously totally unknown to me.

The early retirement was also motivated by other great hobbies like trekking and climbing both of which had been neglected during my long assignments in France, Switzerland, and USA. I am now back to my beloved Italy, close to my mountains and ancestors.



Anselmo Stiffan, IZ3BGJ

antenneX Online Issue No. 107 — March 2006  
Send mail to [webmaster@antennex.com](mailto:webmaster@antennex.com) with questions or comments.  
Copyright © 1988-2006 All rights reserved worldwide - antenneX©